

Carbon Heating Film Installation Instructions

Contents

Page 2	Product Overview
Page 3	Pre-Installation & Electrical Provision
Page 4	Insulation Underlay - Installation
Page 5	Carbon Film Installation - Under Wood/Laminate Flooring
Page 8-9	Floor Sensor Installation
Page 11	Notes & Trouble shooting

Product Overview

Thank you for selecting our electric underfloor heating system. Before you begin installing please **read through these instructions carefully** & check that you have all the components required.

The system requires a mains voltage 230V supply & must be connected in compliance with building regulation Part 'P' approved document and current wiring regulations

Important Notes:

Due to their moisture content, solid and kiln dried wood floor coverings should be laid, but not fixed, to allow acclimatisation with the heating system energised before final fixing. Allowances should be made for expansion. Refer to manufacturers instructions.

Laminate and veneered/engineered flooring needs to have an allowance made for expansion. Refer to manufacturers instructions

The Carbon Heating Film will heat most floor finishes to a temperature of 27°C. This is the limit to which most flooring products can be heated to. Consult flooring manufactures technical details for further information. Please note that the surface temperature of the flooring under rugs and flush or low profile furniture may exceed 27°C if not monitored. For this reason the use of rugs & floor standing soft furnishings such as poufs & beanbags is not advised as damage to the floor finish, heating system and substrate, may result.

If floor finishes such as carpet or are to be installed over the carbon film, a stable floating floor must be constructed. Heat-Pak® flooring is recommended for this application, which is available from your under-floor heating supplier, to give a smooth and thermally conductive sub-floor. The floor covering must be less than 2 Tog

Contents of Heating Kit:

- Carbon heating film with cold connections made
- 6mm Foam Insulation Underlay
- Digital Programmable Thermostat
- Floor Sensor (5-20Kohms)
- Floor plan showing element layout
- 20Amp connectors
- Polyethylene Sheet (Dielectric Membrane)
- Flexible Conduit
- Factory test sheet with individual resistance readings
- Warranty / Guarantee Certificate

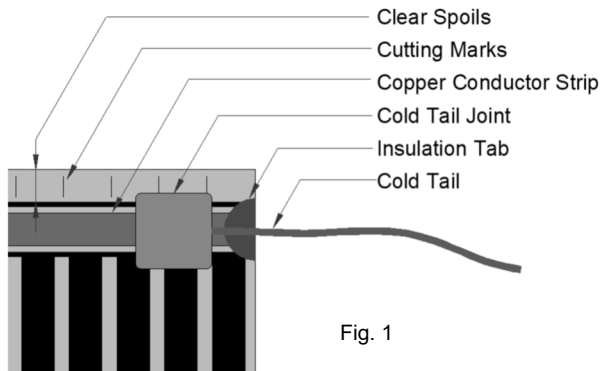

Fig. 1

Pre-Installation

First unpack & identify all components (a list of supplied components is on page 2) and check the layout - see supplied floor plan (example Fig. 2)

Ensure that the sub-floor (concrete or timber) is clean, dry & free from dust & debris. The floor should also be suitably level to take the kind of flooring that you will be laying. Some types of wood plank flooring have a tolerance of just a mm or two per linear metre & we strongly recommend that your floor fitter surveys the floor **before** the heating is installed.

Additional items to aid installation

Stanley/Craft Knife
Double Sided Adhesive Tape
Self Adhesive Cloth Tape (Duct Tape)
Multi-Meter

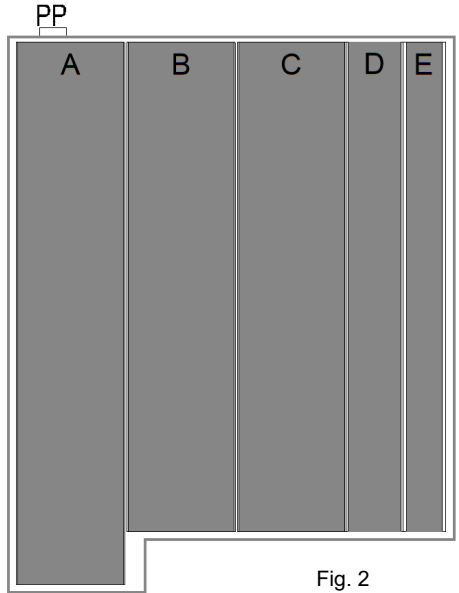

Fig. 2

Electrical Provision

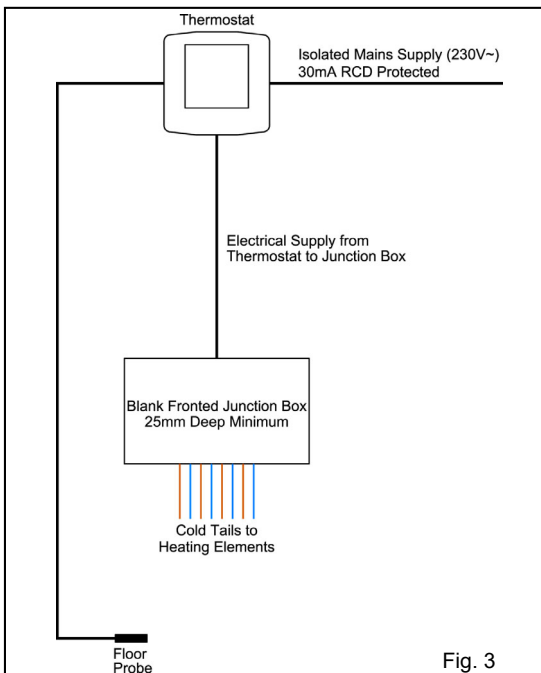

Fig. 3

Make the electrical provision as per the diagram Fig.3. The circuit must incorporate a 30mA RCD protection

For installations below 13Amp, A fused spur or combined spur/ RCD is recommended.

For installations over 13Amp a suitable isolated supply should be provided incorporating 30mA RCD protection.

The thermostat rating varies depending upon which model is being installed. Refer to the thermostat instructions to determine the maximum current that the thermostat can switch. It will be either 15 or 16 Amps (most domestic installations are within this figure). If the system supplied is over the maximum rating of the thermostat it will be subject to a more comprehensive electrical installation. (Your electrician will be able to advise you on this).

Note: all electrical connections should be made in compliance with building regulation Part 'P' and the IEE current wiring regulations

Insulation Underlay - Installation

Notes:

The foam underlay should be cut with a Stanley knife or similar.

Step 1

Once you are satisfied that the sub-floor is suitable (see pre-installation notes page 3), lay out the insulation underlay to cover the entire floor area, except for the 50mm gap. The foam underlay sheets should be laid with staggered joints Fig.4.

If laying a double layer (recommended in conservatories & other areas with a high heat loss) the second layer should be laid at right angles to the first.



Fig. 4

Step 2

Leave a gap of approximately 50mm at one edge of the room along where the cold cables are to be run, so as to allow them to sit flush under the floor covering when it is laid. For systems of more than 8 elements a gap wider than 50mm may be required.

Using a length of 50mm wide double sided tape on the sub floor within the gap that has been made in the underlay, can be used to hold the cold cables in place.

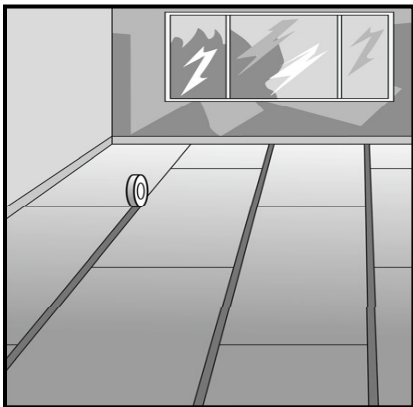

Fig. 5

Step 3

If you wish, you can join the sheets of underlay together to prevent them from moving apart. This can be done by taping the edges of adjoining sheets together with a self adhesive cloth tape (Duct Tape) Fig. 5

Carbon Film Installation Under Wood/Laminate Flooring

Only **LIGHT FOOTWEAR** should be worn. Avoid foot traffic on the heating elements and cold tail joints.

Step 4

Un-pack the heating elements for the room and check that you have all the elements detailed on the enclosed drawing & room test data sheet.

Material	Volts	I.D.	Qty	Element Length (m)	Element Width (m)	Design Resistance Range (Ω)	Actual Resistance (Ω)
500/530	230	A	1	3.65	72	212 - 248	212
			1	3.65	72	212 - 248	248
			1	3.15	72	250 - 292	250
			1	3.15	72	250 - 292	292
			1	3.15	72	250 - 292	250

Element Length (m)	Design Resistance Reading (Ω)		Actual Reading
	From	To	
3.00	212	248	
3.50	212	248	
4.00	250	292	
4.50	250	292	
5.00	250	292	
5.50	250	292	

Step 5

Check the resistance of each element using a suitable electrical testing device. A basic multi-meter will be sufficient to test the elements at this stage.

You can purchase a suitable test device from your underfloor heating supplier or most DIY stores stock similar products.

DO NOT continue without first testing each element.

The desired resistance readings for each element are listed on the enclosed room test data sheet. A sample of the data sheet is shown in fig. 6. The reading should be within the Design Resistance Reading Range e.g a reading of 223Ω for the range circled in the example fig 6 is acceptable.

Note. The cold cables are double Insulated, a coloured outer and a clear inner.

Fig. 6

Step 6

Position the rolled up elements along the edge of the room Fig.7, as per the drawing supplied. When you are satisfied with the position of the elements (ensuring that they will not overlap), roll out the heating elements Fig.8. The elements can be laid either way up, however we recommend they are installed copper face down to aid recessing the cold tail connections into the insulation underlay.

Adjust positioning to obtain the best floor coverage and lightly fix into position with self adhesive cloth tape (duct tape) to avoid movement.

Whilst working around the elements use a board or spare sheet of underlay to spread your weight. **DO NOT** walk directly on the heating elements or cold tail connections.

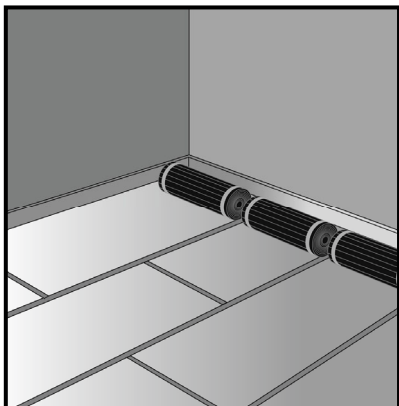

Fig. 7

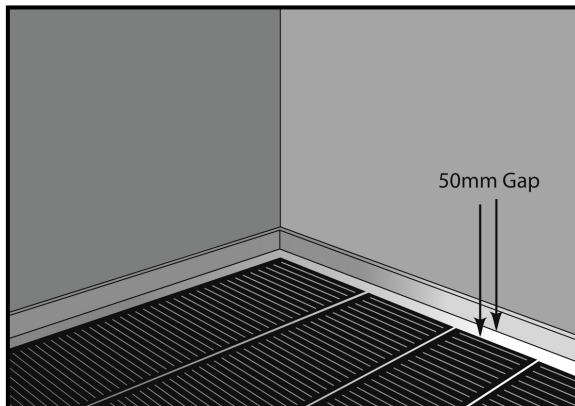

Fig. 8

Step 7

Below each of the "cold tail" joints form a cut out in the foam underlay to allow the plastic cover of the joint and the cold tail itself to lay within the underlay. Fig. 9

The cut out for the cold tail should extend to the 50mm gap at the edge of the room.

If you have installed more than one layer of foam underlay, only form the cut-outs in the top layer.

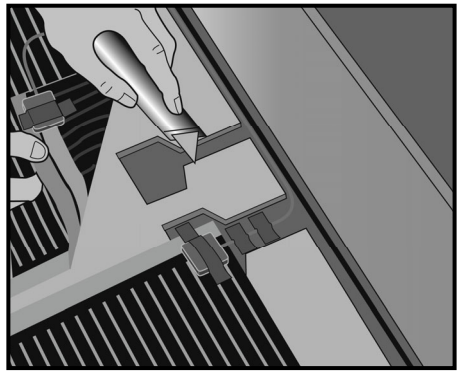

Fig. 9

Step 8

If used, peel the backing from the double sided tape that was fixed into the 50mm gap at the edge of the room.

Starting from the point furthest from the connection box, run the cold tails from each element along the room perimeter, fixing them to the exposed double sided tape or if tape is not used, lay them carefully in the gap.

DO NOT run the cold tails under the heating elements

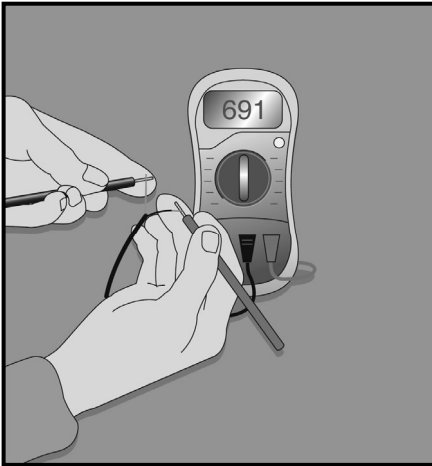

Fig. 10

Step 9

Once the cold tails are in position a resistance test needs to be performed on each individual element for a second time. The desired resistance readings for each element are listed on the enclosed room test data sheet.

Record the actual reading in the box provided on the data sheet. **This is a requirement of the guarantee and MUST be performed at this stage.** The data sheet needs to be retained on site with the heating system.

Note. *The cold cables are double insulated, a coloured outer and a clear inner.*

Step 10

The cold tails can now be joined in parallel at the junction box using the 5-pole electrical connectors provided. See Fig 11a & 11b

The junction box should be a double gang blank fronted box of a minimum 25mm depth. Fig. 11,

The paralleled cold tails should be routed to the junction box and connected to a suitably sized supply cable from the thermostat. See Fig. 2 Page 3

Note. *The cold cables are double insulated, a coloured outer and a clear inner.*

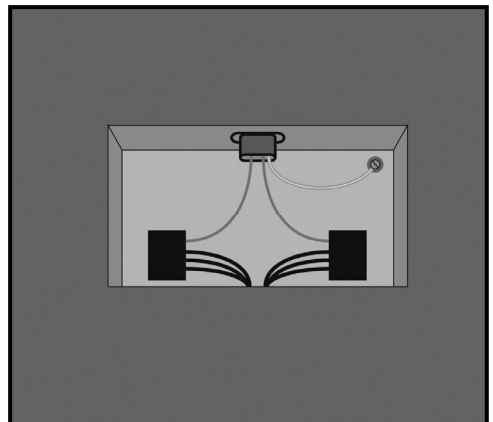

Fig. 11

Carbon Film Cold Tail Connections

Fig. 11a

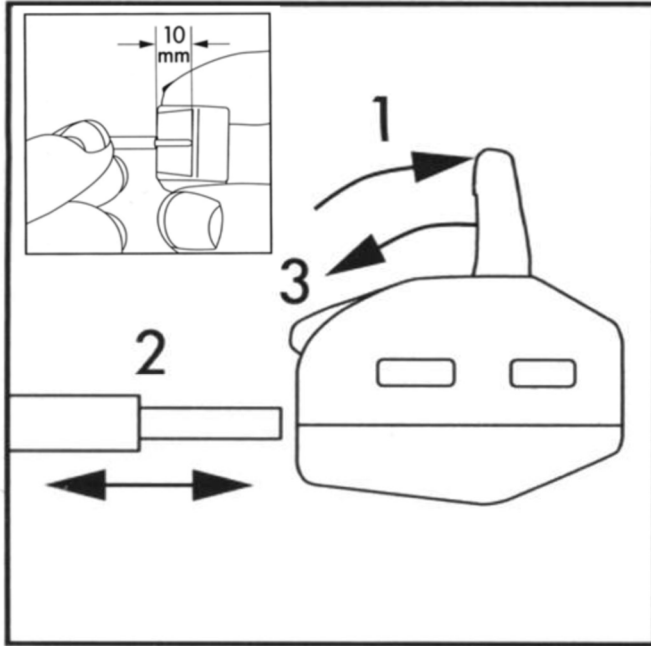
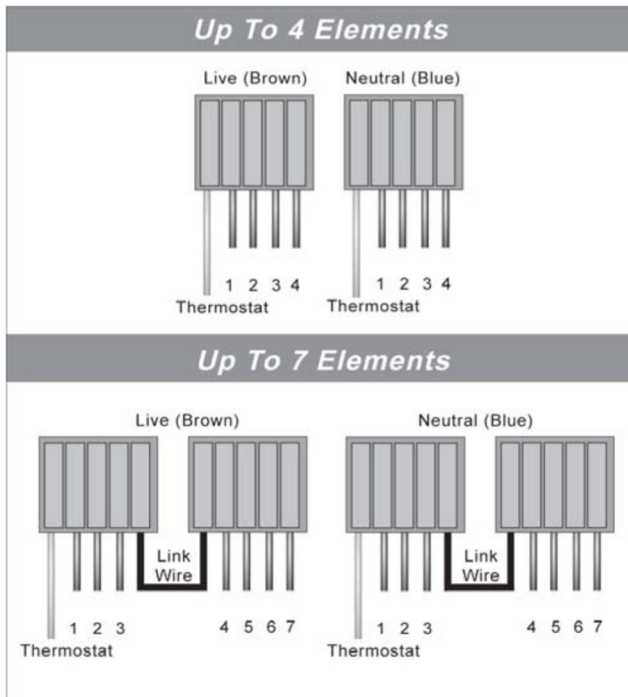

Fig. 11b



Floor Sensor Conduit Installation

Each System is supplied with a length of 10mm flexible conduit (only one tube is required for each thermostat), this is for the floor sensor/probe, so that in the unlikely event that it fails, it can be easily removed and replaced.

Installation of the conduit should be done carefully to make the bends as smooth and shallow as possible. The floor probe should read between 5-20 K ohms

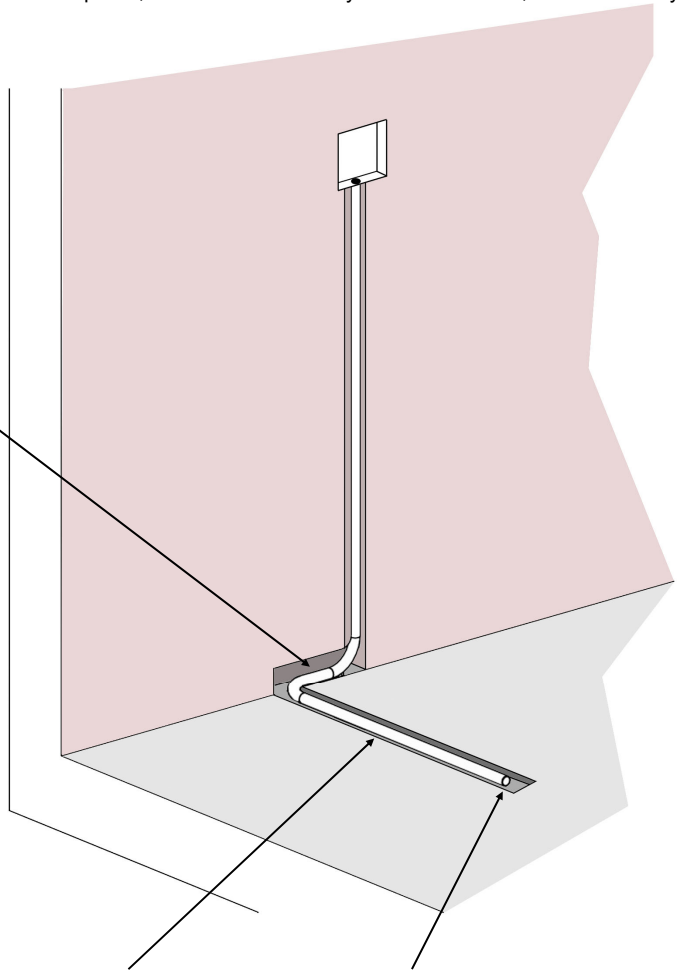

In some situations a small channel may have to be made in the floor to accommodate the tubing. If so, cut a channel from the thermostat position approximately 30-50cm in from the edge of the room

It is important that the channel is positioned so that it lays between two heating elements and not across them.

The end of the conduit that is in the floor should allow the tip of the probe to be exposed, so that it is in contact with the underside of the finished floor.

Step 12

When you are satisfied with the layout, cover the heating elements with the 200 micron dielectric membrane (plastic sheet) provided. The joints of the sheeting have to overlap by at least 20 cm. These overlaps have to be sealed over their total length with a self-adhesive PVC cloth tape (Duct Tape)

Step 13

The floor finish can now be laid directly over the moisture barrier in accordance with the flooring manufacturer's instructions. **Under no circumstances** should a separate underlay be installed at any point between the heating element and the floor finish. Ensure that the floor finish has been acclimatised prior to installation to avoid excessive shrinkage when heated. Refer to the notes on page 2 of this manual.

During the process of laying the floor, care should be taken not to damage any of the heating elements or cold tails. A spare sheet of foam underlay or a board, can be used to kneel on to help spread weight.

Step 14

Once the floor finish has been laid, perform resistance tests on the floor probe and across the feed cable that connects the thermostat to the junction box, to ensure that no elements have been damaged during the flooring installation. The desired resistance reading for the heating system is at the bottom of the room test data sheet and should be within the tolerance of +10 –5%. Record the final readings on the guarantee certificate. Once this test has been completed, final connections to the thermostat can be made. See Separate installation instructions for the thermostat.

For help and advice regarding this product, please contact the
Floor Heating Helpline: 0115 963 2342

!! WARNING !!

**THERMAL BLOCKS PLACED OVER
THIS SYSTEM MAY DAMAGE :**

- THE FLOOR COVERING
- THE UNDERFLOOR HEATING SYSTEM

If in any doubt give us a call 0115 963 2342

Notes

1. Electric underfloor heating is designed to run at low temperatures and can have a slightly slower warm-up time than conventional heating. This can be countered by using the features of the programmable thermostat instead of switching the system on or off.
2. If installed in new buildings and especially conservatories, the heating period may be affected by the moisture content within the building. All new floor constructions and new buildings should be fully dried out before fitting wood, engineered wood or laminate flooring.
3. The carbon film heating system is primarily designed to heat wood, engineered wood or laminate flooring. With such materials it is important to control the temperature to which they are heated. The industry standard for most wood flooring products is 27°C. Be aware that the carbon film heating system is capable of heating above this temperature and is only limited by the thermostat and the temperatures that it is set to operate to.

Electrical Notes

To satisfy the requirements of an acceptable British Standard a double sheathed single core cable to BS.6004 must be used under floors. All our cold cables comply to this standard.

Each individual heating element is designed to accommodate a current carrying capacity of up to 10Amps and should be connected **in parallel** at the junction box.

Consideration must be given by the electrical contractor in respect of the individual heating circuit ratings relative to the thermostat rating, circuit breakers, interconnecting cable sizing and switched contactors where the load of the heating system exceeds the rating of a single thermostat. Good wiring practice must be observed and the wiring must comply with the current wiring regulation

The electrical installation must incorporate a 30mA RCD Protection

Trouble shooting & FAQ's

- Q.** When I perform the resistance test on the heating element I cannot get a reading.
A. Check that the test equipment you are using is set to read Ω and that both the inner and outer cable insulation sheaths have been removed.
- Q.** What size cable should be used to connect the thermostat to the junction box?
A. The size of the cable will vary depending upon the electrical load required for the heating system. Therefore this cable needs to be correctly sized by the electrician.
- Q.** The heating elements are slightly too long, can they be cut?
A. Yes. The element should be cut across it's width, along a clear section, in line with the cutting marks on either edge of the element. Once cut, the ends of the copper conductors needs to be sealed either re-using the green stickers from the end of the off-cut or use electrical insulation tape.
- Q.** Can the elements be overlapped?
A. Under no circumstances should the heated areas of the elements be overlapped. Only the clear spoils at the edge of the element can be overlapped

These instructions are correct at time of printing

For help and advice regarding this product, please contact the
Floor Heating Helpline: 0115 963 2342

Do's & Don'ts

Do's

- DO** Ensure that the electrical supply is protected by a 30mA RCD
- DO** Use light footwear when installing the heating system
- DO** Test the heating elements and floor sensor before and after fitting the floor finish
- DO** Install the heating elements with the copper conductor facing down
- DO** Install the floor sensor within the flexible conduit provided
- DO** Acclimatise floor finishes such as wood or engineered wood before fitting
- DO** Complete the guarantee certificate and retain on site with the heating system
- DO** Ensure that the final floor finish is suitable for use with this product

Don'ts

- DON'T** Install carbon film in a bathroom or shower room
- DON'T** Overlap the heated parts of the heating elements
- DON'T** Run cold tails under the heating elements
- DON'T** Place rugs, thermal blocks or floor standing soft furnishings (e.g poufs or beanbags) over heated parts of the floor
- DON'T** Make cold tail connection under the floor finish
- DON'T** Fit a floor covering of more than 2 Tog

These instructions are correct at time of printing

For help and advice regarding this product, please contact the

Floor Heating Helpline: 0115 963 2342

Carbon Heating Film Lifetime Warranty / Guarantee

Instructions for completing the Warranty / Guarantee Certificate

Step 1 Complete section 1 overleaf, which is the contact details for both the installer and the client where the system has been installed. Ensure all information provided is complete and accurate with special attention to items listed below:

Signed This is the signature of the installer

Part P Reg This is the installers professional association registration number

Date This is the completion date of the underfloor heating installation

Client Details The name of the client and the installation address including the postcode **MUST** be complete.

Step 2 Complete section 2 overleaf, which is the heating element & floor probe test report. Total Circuit Resistance readings need to be taken (see instructions for details) and recorded in the relevant boxes in section 2. **ALL** boxes must be completed.

As with the heating element, **ALL** boxes within the floor probe test report must be completed.

Step 3 Keep this guarantee along with the room test data sheet at the property where the heating system has been installed, for future reference

The report needs to be submitted onto the guarantee database. This can be done online at: sales@floorheatingsystems.co.uk

If you do not have internet access you can send a copy of the completed test report to us and we will submit the form onto the database on your behalf

Floor Heating Systems Ltd
Fairway Court,
Wigwam Lane
Hucknall,
Nottinghamshire
NG15 7TA

Carbon Heating Film Lifetime Warranty / Guarantee

Terms and Conditions of Warranty / Guarantee

The Carbon Film is warranted for a period 10 years of the life of the floor covering under which it is fitted, as long as the product is installed in accordance with our latest fitting instructions, and the installation conforms to Part P of the building regulations and current wiring regulations, with the exceptions provided below:

The Thermostat is guaranteed for a period of 5 Years, with the exceptions provided below:

Exceptions

The system is not protected by a Residual Current Device (RCD).
This Guarantee is not completed correctly by a competent person as above.

Floor Heating Systems Ltd is not responsible for:

- Damage or repair of a faulty installation
- Damage from atmospheric conditions or other conditions beyond our control (force majeure etc)
- Products installed outside of the United Kingdom
- Parts not supplied by ourselves
- Damage or repairs due to or caused by improper use
- Damage or failure due to interruption / inadequate electrical service

During the guarantee period we will repair either the heating element or thermostat or (at our discretion) have parts replaced free of charge. The cost of repair or replacement is your only remedy under this guarantee which does not affect you statutory rights. Costs do not extend to any other than the cost of repair or replacement; it does not extend to costs of repairing / replacing any of the floor, sub-floor or its coverings. This guarantee must be available to Floor Heating Systems Ltd before any repair / replacement will be honoured.

Lifetime Warranty / Guarantee Installation Test Report Sections 1 & 2

Section 1

Company Name:	
Installer Name:	
Address :	
Signed :	
Part P Reg No:	Date:

Client Name:	
Address:	
City/Town:	
County:	
Postcode	Telephone:

Section 2

Heating Elements				
REF This can be found at the top of the room test data sheet	Total Wattage (W)	Design Resistance Ohms (Ω)	Total Resistance Before Fitting Floor Finish Ohms (Ω)	Total Resistance After Fitting Floor Finish Ohms (Ω)

Floor Probe	
Actual Reading Before Fitting Kilo Ohms ($k\Omega$)	Actual Reading After Fitting Kilo Ohms ($k\Omega$)